



## PART # 9433

### FORD 429-460 MOTOR MOUNT KIT (Not For Lincoln Engines)

Designed to install the big block 429-460 Ford engine into  
1967-69 4WD F-250 Ford Pickup, 1978-79 Bronco and  
1978-79 F-150 4WD Ford Pickup.

**This kit requires the use of the following (*obsolete*) Ford Parts to complete the installation. You may want to check your local salvage yard:**

The following Ford Motor Mounts and Shells from a 1973 to 1979 2WD Ford F250 or F350 with a 460 factory engine.

1 Pair FOMOCO or NAPA motor mounts part #D3TZ6038A

1 each FOMOCO motor mount shells Right side #D3TZ6030A & Left side #D3TZ6031A.

## INSTALLATION INSTRUCTIONS

**WARNING!** In order to complete the installation, your truck must be raised a minimum of 36 inches. We recommend the use of a floor hoist. If no hoist is available, use axle stands as a safety measure. NEVER support your truck with only a bumper jack. An engine hoist, sufficiently rated to support the engine's weight, is necessary to install and position the engine.

1. Disconnect the battery.
2. Disconnect, mark and label all wires, cables and hoses, etc.
3. Remove hood, radiator and engine. If using stock transmission, leave it in.
4. Remove the original engine stands from the frame.
5. Using the original engine stand bolts, install the Trans-Dapt motor mount stands on the frame (See figure 1 below). The long stand goes on the left side (driver's side) and the short stand goes on the right side (passenger's side). DO NOT TIGHTEN BOLTS COMPLETELY.
6. Bolt the Ford motor mounts and shells to the engine. Shell #D3TZ6031A goes on the left side (driver's side) of the engine. Shell #D3TZ6030A goes on the right side (passenger's side) of the engine.
7. Using an engine hoist, lower the engine into the chassis. Bolt up the transmission to the engine. Then bolt the engine to the motor mount stands. NOW TIGHTEN ALL BOLTS.
8. Install the radiator. Connect all cables, wires, etc.
9. We recommend the use of heavy duty front springs to carry the larger engine.

For 1977½-79 ONLY  
Drill matching hole  
thru frame & install  
7/16-14 bolt.

FIGURE 1

LEFT SIDE SHOWN  
RIGHT SIDE SIMILAR

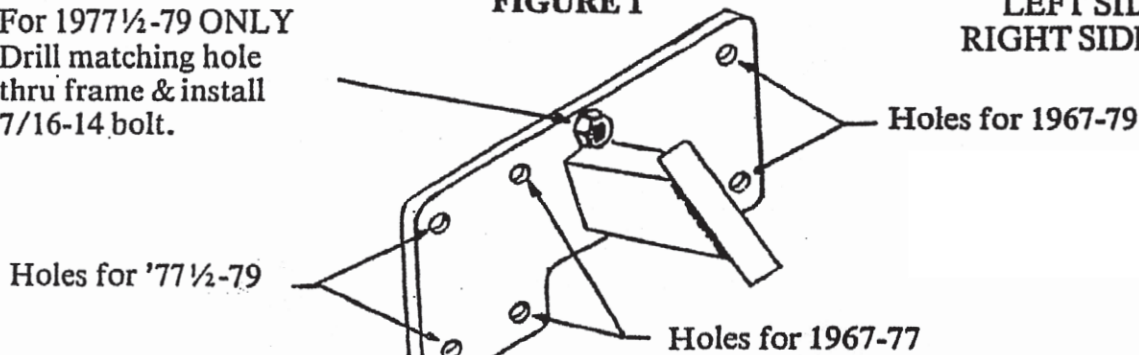

**NOTE: ON 1977½-79 MODELS WITH LEAF SPRING FRONT END ONLY, THE HOLES IN THE FRAME DO NOT MATCH THE HOLES IN THE TRANS-DAPT MOTOR MOUNT STANDS. PLEASE FOLLOW THE STEPS BELOW FOR THESE MODELS:**

- A. Bolt the motor mount stands to the engine.
- B. Support the engine and transmission in place in the chassis of the truck.
- C. Transfer the existing frame hole locations onto the sideplates of the Trans-Dapt motor mount stands.
- D. Drill bolt holes in the sideplates and bolt the stands to the frame. Weld the sideplates to the frame if so desired.

12438 Putnam Street • Whittier, CA 90602 tel (562) 921-0404 • fax (562) 921-7515  
website: [www.hedman.com](http://www.hedman.com) • email: [techsupport@hedman.com](mailto:techsupport@hedman.com)