

INSTALLATION GUIDE

PART# 4606, 4626

ENGINE MOUNT KIT

**Installs a CHEVY 4.3L V6 ENGINE into 1982-2004 2WD (only)
CHEVY/GMC S-10/S-15 TRUCKS with FACTORY 2.2 or 2.8L ENGINE**

THIS KIT INCLUDES:

QTY.	PART #	DESCRIPTION
1 pr.	4626	Pair of Engine Brackets
2 pc.	4217	Frame Mount Pads (4606 Kit Only)
6 pc.	HDW366	3/8"-16 x 1" Grade 8 Hex Head Bolts
2 pc.	HDW969	7/16"-14 x 5" Grade 8 Hex Head Bolts

QTY.	PART #	DESCRIPTION
6 pc.	HDW321	3/8" Split Lock Washers
4 pc.	HDW421	7/16" Flat Washers
2 pc.	HDW053	7/16"-14 Nylon Insert Lock Nuts

INSTALLATION GUIDE

The engine brackets in this kit are designed to bolt to the factory rubber S-10 2.2 or 2.8L V6 engine pads, or Trans-Dapt's #4217 mount pads (included with kit #4606, not included with #4626).

1. If not installed already, bolt the factory (or included) frame pads to the crossmember using the factory hardware. When properly oriented, there is one bolt on the top of the frame pad, and two bolts on the bottom of the frame pad.
2. Following the engine bracket orientation shown (ill. a), loosely bolt the engine brackets to the 4.3L engine block using three 3/8"-16 hex bolts and lockwashers per side. Do not fully tighten the bolts, at this time.
3. Position the engine in the engine bay, lower the engine into position and connect the frame pad to engine bracket using a supplied 5" hex bolt, 2 flat washers and lock nut through the slots in the engine brackets and hole in the rubber pad on each side of the engine. Do not tighten yet.
4. With the engine properly located, tighten the mount pads to the crossmember. Next, tighten the engine brackets to the engine block, then tighten the 5" through bolts that connect the pads to the engine brackets.

No drive shaft modifications are required when used with a TH350 or original T4/T5 transmission.

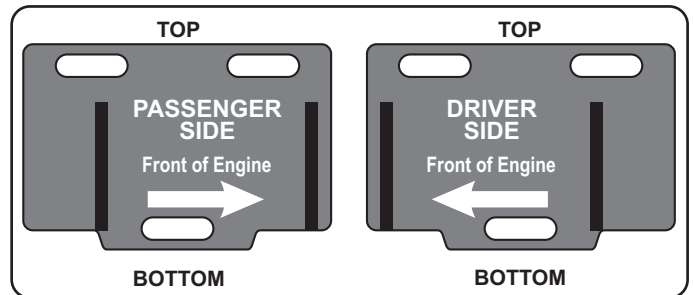

(ill. a)

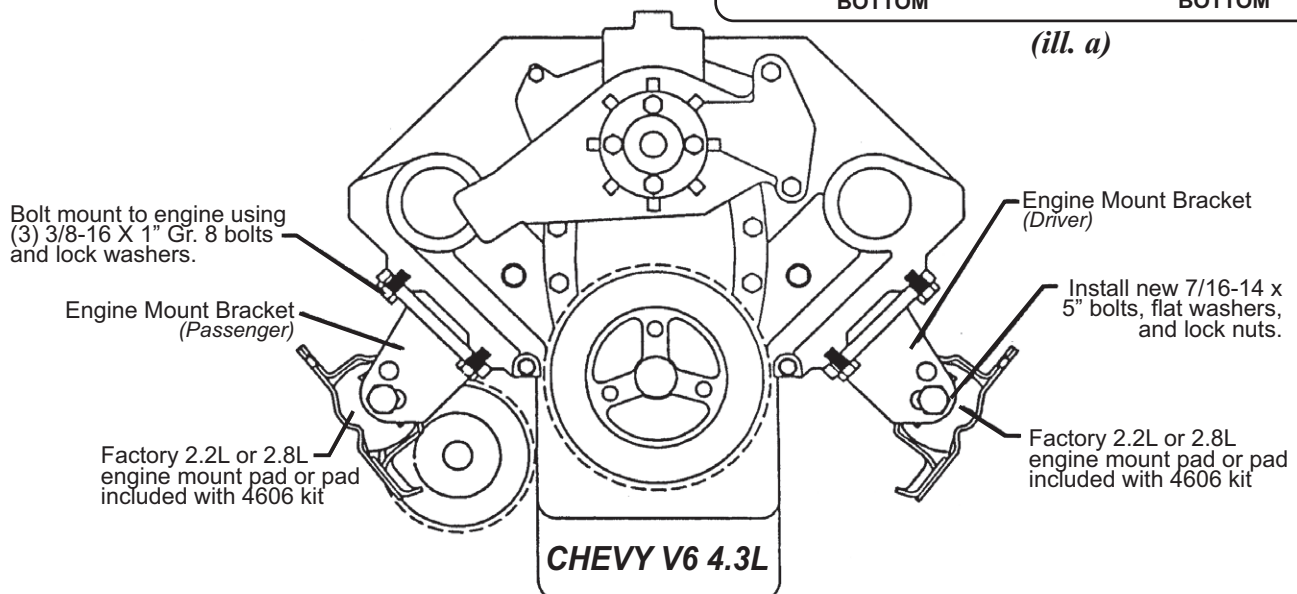

Special Note: The components packaged in this kit have been assembled and machined for a specific type of conversion. Modification to any of the kit's components will void warranty and return privileges. If you do not fully understand the modifications or changes required to complete your conversion, we strongly recommend that you contact our tech department for more information. There are many aspects to consider when performing this engine swap. This instruction guide assists with the installation of Trans-Dapt's engine mounts, only. It is recommended that a service manual for the vehicle be obtained, to ensure access to proper tightening torque specifications, wiring diagrams, and other important details surrounding your S10/S15 project.